

Pore Size Meter for Filter Papers, Non-Woven, Woven Materials and other Porous Materials

PSM 165



Pore Size Meter PSM 165

The unique Pore Size Meter PSM 165 provides pore size information for a wide range of porous materials with applications in the field of filtration, hygiene and tissue engineering. Materials that may be tested include filter papers, micro sieves, non-woven as well as woven materials and sintered polymers or metals.

The operator is guided through the test procedure by an easy to use software package PSMWin running on a standard PC.

The following parameters describing the inner structure of the material can be obtained with this compact measuring instrument:

Bubble Point Pressure drop at which the wetted sample starts to become gas permeable, corresponds to the largest single pore.

Pore size distribution Permeability weighted pore size distribution calculated from the differential pressure -flow rate measurement in Dry Flow and Wet Flow sample

Specific gas flow rate Cross-section-related gas volume flow measured at selectable differential pressure of dry sample

Special Advantages

- High accuracy especially for pores > 10 microns, particularly relevant for non-woven fabrics and open-pore samples
- Open concept for sample holder, manual bubble point measurement is possible, which is necessary for particularly dense samples
- Custom sample holder adapted for the measurement of various test specimens
- Computer controlled test procedure and user friendly data acquisition and presentation in Windows environment
- User defined test fluid

Applications

- Development of porous materials
- Quality Control, Incoming goods inspection

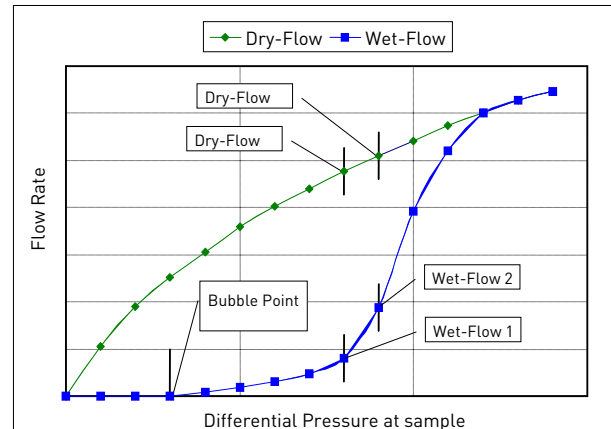

Measured pressure drop vs. flowrate for a dry and wetted sample of non-woven material

The pressure drop across the filter media sample is measured as a function of the gas flow rate through the sample for the dry and the wetted sample material. As a test fluid Topor (perfluoro compound, Topas specific testing fluid) is recommended due to its excellent wetting behavior. Data acquisition and processing is completely computerized guiding the operator with specific instructions.



Principle of Operation

Principle of Operation

The basic principle of pore size measurements is that liquid filled pores will become gas permeable at a certain gas flow pressure. This initial differential pressure indicates the bubble point of a material.

As real materials contain a range of pore sizes, the bubble point corresponds to the opening pressure of the largest pore. The measured pressure value is dependent on the surface tension of the test fluid used.

By further increasing the gas flow rate, and therefore the pressure drop across the material under test, it is possible to calculate a pore size distribution from these two measured parameters.

The applied measuring principle is in close accordance with ASTM E 1294-89 and ASTM F 316-03 standards. In addition to Topor, measurements can be carried out with a range of other test fluids. To achieve reliable results the surface tension of the test fluid must be known and a sufficient wetting of the test sample has to be guaranteed.

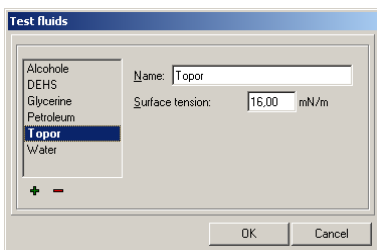

Dialog window for choosing a test fluid

Flow Scheme of PSM 165

The basic configuration of the device is shown in the following figure. Two high-precision mass flow controllers are used to generate a defined flowrate which is passed through the test sample. The resulting differential pressure is measured by pressure sensors which can be customized to provide the best possible result for a specific sample type.

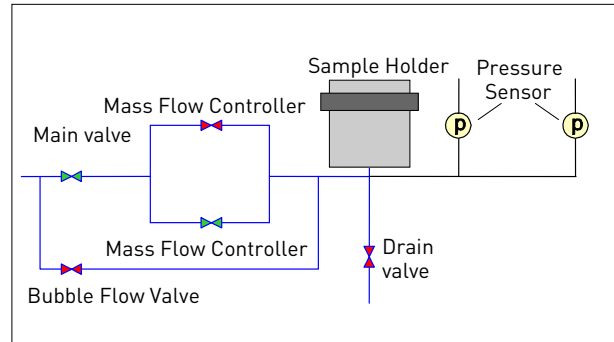

Basic setup of the PSM 165

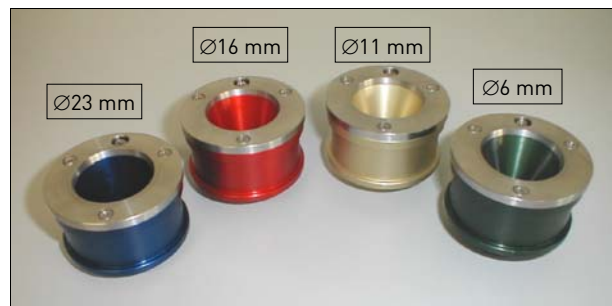

Colour-coded adapters for clamping the sample



Inserted probe



Software PSMWin

The specially developed data acquisition and control software PSMWin is easy to use, and features some of the following functions:

- Guiding the operator through the whole test procedure
- Automated test procedure
- Data presentation with protocol printout
- Dynamic data exchange with Excel and via "copy and paste" for other applications
- Pore size calculator

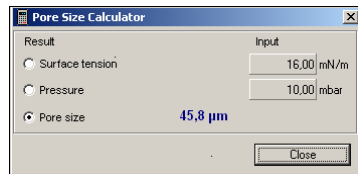
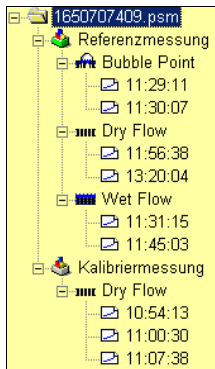

Pore size calculator for evaluation of the measuring range

Test file structure

As the test procedure is fully automated, the operator must only perform the sample preparation. The measurement itself is done automatically recording pressure drop and flow rate data during the test. Necessary adjustments of test parameters to different sample properties can be done easily via the software.

The measuring range of the PSM 165 depends on the specified pressure transducers and the test fluid used for the wet flow measurement. For a fast evaluation of measurable pore sizes there is a pore size calculator implemented in the software.

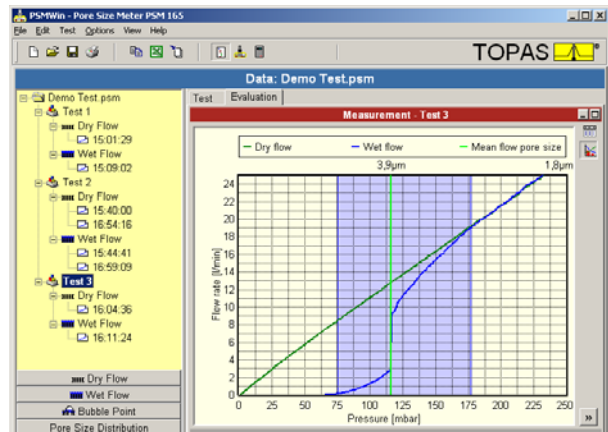

Measuring data window with a dry flow curve (green) and a wet flow curve (blue); light blue colored background: analyzed pressure range

The figure above shows an example of flow curves generated during a measurement. The dry flow curve (green) shows a typical continuous increase of the pressure drop across the sample as flowrate increases. The wet flow curve (blue) starts to increase at the initial bubble point pressure and converges to the dry flow curve at increased flow rates.

A new test file with detailed sample information and test data is easily created by completing the dialog form before starting a measurement.

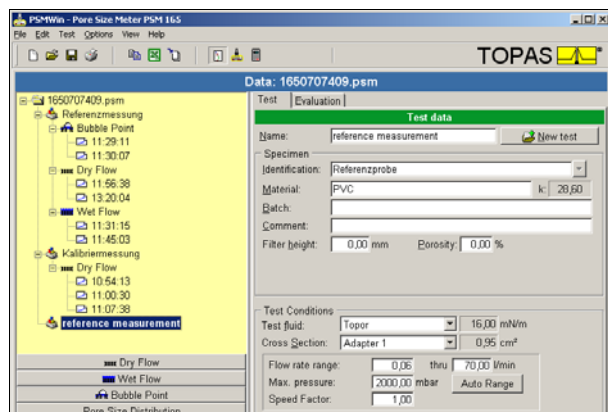

Input dialog for sample data and test conditions



Specifications

Measurement results may be presented in customized reports using PSMWin software. In addition, results can be exported to MS-office applications (Excel) and printed out as a clearly arranged measurement report.

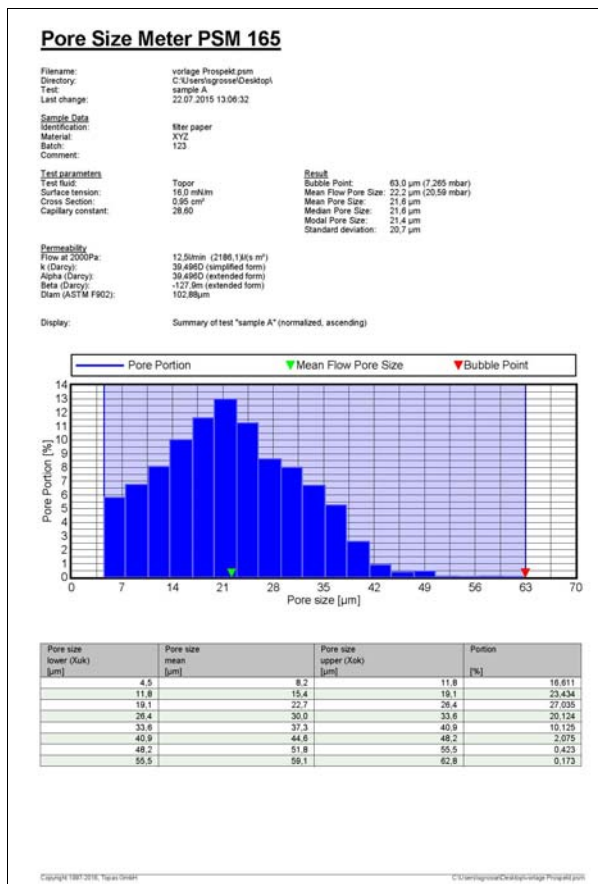

Print out of a measurement protocol

Technical Data

Measuring range:

PSM 165/U (3.5-1000 mbar) 0.5...130 µm (Topor)

PSM 165/L (0.2-350 mbar) 1.3...250 µm (Topor)

PSM 165/H (3.5-2000 mbar) 0.25...130 µm (Topor)

Sample adapters 6 mm, 11 mm, 16 mm, 23 mm (exchangeable)*

Sample dimensions Diameter: 10...40 mm
 Sample thickness: 0...15 mm

Flow rate 3.6 l/h...4200 l/h
 0,06 ... 70 l/min

Type Desktop device with standard RS 232 interface and Windows data acquisition as well as control software PSMWin

Compressed air supply 4 bar; 5 Nm³/h

Power supply 110...230 V AC

Size 480 x 390 x 310 mm

Weight 12 kg

* other customized adapters on demand

QMS certified to DIN EN ISO 9001



12 100 11908 TMS

For more information please visit our website at www.topas-gmbh.de

Specifications are subject to change without notice.

© Copyright 2016 Topas GmbH.

