



## • AST SRU FO

350°C to 2000°C

### Features

- Two Channel for measurement of Refractory, Gas Temperatures and smart hybrid temperature
- Explosion-Proof Certification II 2G Ex db IIC +H2 T3, IECEx, ATEX, FM (US and CDN)
- CE Certifications (EMI/RFI)
- Fast Response Time : 2ms to 10Sec. (Analog)
- Fiber Optic Cable withstand up to 250°C ambient
- Wide Temperature range: 350°C to 2000°C
- Two analog outputs(4-20mA and 0-20mA), two relay outputs, Analog Sub range adjustable(350-2000 °C) and RS485 Interface.
- OLED Display (128×64) with keypad
- RS-485 Serial Interface
- User Friendly PC software for communication

### Standard Scope of Supply

- 2.5 mtr Mono Fibre optic cable of 500µ (5, 10 mtr. optional)
- Optical head OH(II)
- Analog Output 4...20mA, 0 - 20mA
- RS-485 digital interface
- 5 mtr long connection cable with connector
- Calibration Certificate, Explosion Proof Certificate for enclosure, PC Software & Operation manual

### Optional

- Mechanical and Electrical Accessories
- Extra Lengths of Fiber Cable and Connection cable

### Applications

- Sulphur Recovery Units
- Petrochemical emission Monitoring
- Thermal Oxidizer Monitoring
- Other High Temperature Furnaces

## • AST SRU FO

Explosion Proof Digital IR Fibre Optic Pyrometer with Mono Fiber Optic Cable



The AST SRU FO is a two channel model for measurement of refractory temperature, gas temperature and smart hybrid temperature. It is highly accurate digital Fibre Optic industrial IR Pyrometers, for non contact temperature measurement in demanding applications. Infrared Thermometry Fibre Optic Pyrometers are widely used in high ambient temperature and explosion proof applications without cooling and also in processes involving digital interferences. With very fast response time of 2ms to 10 sec. The pyrometer provided with RS-485 for communication between pyrometer & PC Software. The parameters such Emissivity, Transmissivity Response time, Analog output, Analog Scale (Sub range), Channel selection, Clear Time, Temperature Unit and record feature can be adjusted remotely via PC software.

### Software “Infrasoft”

AST “Infrasoft” software is under standard scope of supply. It offers possibilities of connecting three pyrometers simultaneously for parameter setting, view real time graph, offline graph and to evaluate measuring data. Communication between the pyrometer and the software is implemented via a cable connected between the pyrometer and the PC serial port. It comes with record feature, spot size calculator and parameter settings features.

Some of the parameters adjustable via software are

- Emissivity, Response Time
- Clear Time(Peak Picker)
- Analog Output
- Sub Range
- Unit Of Temperature(°C/°F)
- Communication mode(Comm.mode)

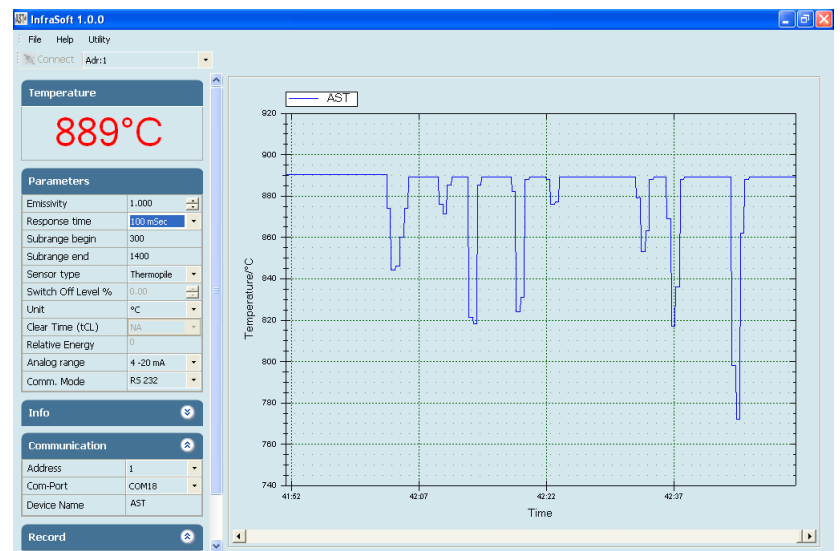

## Technical Specifications

Model	AST SRU FO
Temperature Range (Analog sub-range adjustable)	350°C....2000°C
Distance to Spot Size Ratio	100:1 OH(II)
Transmittivity	0.1....1.0 adjustable
Emissivity (ε)	0.01....1.0 adjustable
Response Time	2 msec adjustable upto 10 sec (for Analog)
Accuracy	± 0.25% of the measured value + 1°C
Repeatability	0.1% of reading in °C + 1°C
Analog Output	0-20mA, 4-20mA (User selectable)
Digital Output	RS-485
Area Classification	Zone 1 and 2 II C T3
Relay	Output with Hysteresis 60V DC / 42V AC RMS, 0.4A
Operating Temp. Range	Pyrometer 0°C.....70°C Optical head and Fibre Optic Cable upto 250°C
Storage Temp. Range	-20°C...70°C
Adjustable Parameters and Features via Software	Emissivity, Transmissivity Response Time, Clear Time(Peak Picker), Analog Output, Analog Scale (Sub Range), Unit Of Temperature(°C/°F), Record feature etc
Power Supply	12V to 28V DC with reverse polarity protection
Power Consumption	Max 2.5 W
Protection Class	Explosion Proof
Housing	Di-Cast Aluminium
Isolation	Power supply, *Digital output and Analog output are galvanically isolated against each other
Operating Humidity	10-95%, Non-Condensing Conditions
Weight & Dimensions	Length=133 x 156.60(mm)

We measure accurate temperature in extreme conditions

## Spot Sizes

Fixed Optics	AST SRU FO	
Optical Head	Working Distances (mm)	Spot Sizes(mm) 350°C - 2000°C
	600	6.0
	1000	10.0
	2000	20.0
	4500	45.0
	Aperture(mm)	18.0

Example of OH(II)

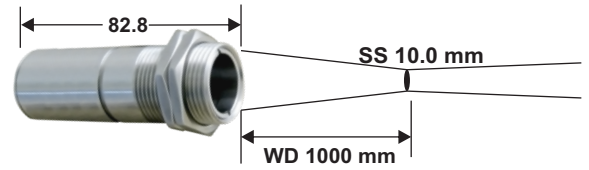

Pull Out (P) = 1.7 mm  
Optical Head Length (L) = 68.1 mm

## Pyrometer Drawings

OH2

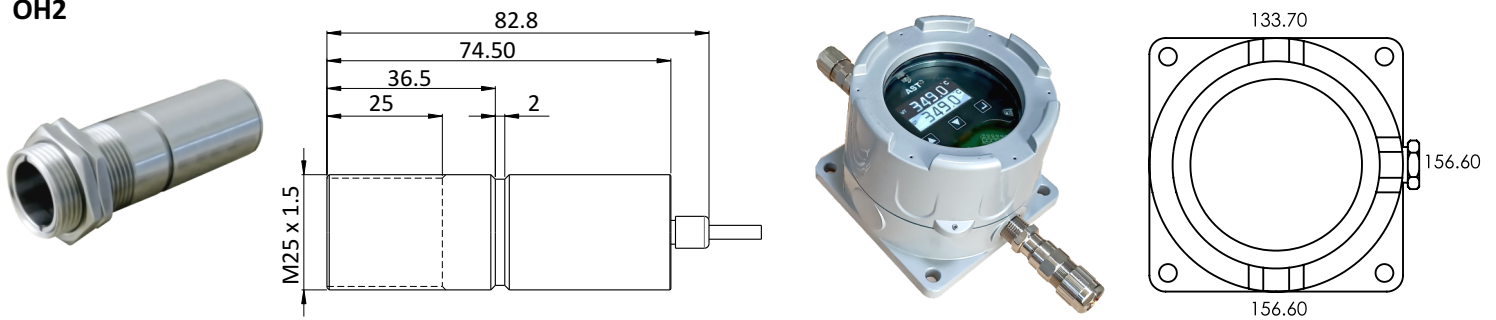

## Accessories

Power supply Input 110/230V AC  
Reference No. 9000 - 02  
Output 24 V DC, 0.7Amp

Temperature Indicator with  
retransmission output 4..20mA  
Reference No. 9000 - 01

Converter RS-485 ↔ RS-232  
Reference No. 9000-03



**Accurate Sensors Technologies Pvt. Ltd.**  
Misgav Industrial Park, Misgav 20174 Israel  
Phone :+972-4-9990025, Fax : +972-4-9990031  
E-mail : info@accuratesensors.com

**Accurate Sensing Technologies Pvt. Ltd.**  
188A, B-169 (Part), B-188 (A), Road No. - 5, M. I. A.,  
Madri, Udaipur (Rajasthan) - 313003  
Phone : +91-9352506032  
Email : sales@astinfrared.com

**AST**  
Accurate Sensors Technologies